



USER MANUAL

NKON ESS Pro - 51.2V 32kWh

OUR PRODUCTS ARE ALWAYS EVOLVING, SO THE UNIT DEPICTED BELOW MAY DIFFER SLIGHTLY FROM THE UNIT YOU RECEIVE.



Contents

USER MANUAL	1
Disclaimer	3
Datasheet	4
Inverter settings (if applicable)	5
Product Packing List	6
Functionality	7
Dimensions.....	8
Installation Instructions	9
Choose a suitable installation location	9
Parallel communication	10
No dial required	10
Communication Description	11
Communication.....	11
Matching inverter communication	11
Internal Communications.....	12
Basic working modes	13
Charging Mode.....	13
Discharge Mode	13
Standby Mode.....	13
Shutdown Mode	13
LED light indication	14
LED light sequence.....	14
Capacity indication.....	14
Flashing instructions	14
Status Indication	15
Battery protection parameters	16
Packaging	29
Getting in touch	30

Disclaimer



This unit is heavy
This unit tips the scales at 233KG, please ensure you have adequate lifting / manoeuvring equipment in place. Before setting it up, make sure children and your (best) friends are not nearby.

- Do not disassemble the product without our express permission, otherwise the warranty will be voided
- Wear proper safety gear such as gloves and eye protection
- Do not reverse polarity
- Do not connect with any batteries in series
- Ensure the system is properly grounded
- Always use insulated tools
- Do not work on battery with it turned on or with the grid turned on
- Do not connect battery to solar wiring directly
- Make sure all fasteners are properly torqued
- Ensure your chargers/inverters are appropriately programmed
- Use only on 51.2v nominal systems, do not connect with other batteries
- Ensure the installation follows applicable local, national and all legal electric stipulations
- Installation should be done by a qualified and knowledgeable person
- Make sure proper cable sizes and overcurrent protection are utilised
- Ensure the system is installed in a location suitable for electronics
- Keep the battery within safe operational temperatures
- Do not put the battery in a hazardous, hot or flammable environment
- Install your equipment in a location where children and pets are not present
- Do not paint, or spray paint the battery

If there are any electrical smells or excessive heat, use your breaker switch and contact your local fire station

Only clean the battery with a dry cloth - do not use any liquids, spray cleaners, aerosols or any type of solvents.

Datasheet

Battery configuration	2P16S
Rated voltage	51.2V
Operating voltage range	43.2V ~ 58.4V
Rated capacity	628Ah
Energy	32.15 kWh
Standard charge/discharge current	300A @ 25±2°C
Operating temperature	0 ~ 40°C (Charge) -20 ~ 40°C (Discharge)
Storage temperature & humidity	-10°C ~ 35°C (≤1 month) 25±2°C (≤3 months) 65% ±20% RH
Dimensions (L × W × H)	(538) × (416) × (818) mm
Weight	230 kg ±3 kg
Cycle life	8000 cycles at 70% SOH (25°C ± 1P 2.5V ~ 3.65V)
IP rating	IP20
Communication	CAN & RS485
Altitude	0 – 3000 m
Humidity range	5 – 75%

Inverter settings (if applicable)

Function / Stage	Purpose	Settings
Battery Type	Selects manual lithium profile	User-defined (LiFePO ₄)
Nominal Voltage	Base system voltage	51.2 V
Bulk / Absorption Voltage	Full-charge voltage (\approx 100 % SOC)	57.6 V
Float Voltage	Maintains full charge without stress	55.2 V
Absorption Time	Duration at bulk voltage for balancing	20 – 30 min
Re-bulk / Charge Return Voltage	Triggers recharge after drop	52.8 V
Low DC Cut-off Voltage	Protects cells from over-discharge	43.2 V
Low DC Restart Voltage	Allows discharge again after recovery	48.0 V
Equalization	Not used for LiFePO ₄	Disabled
Temperature Compensation	Prevents incorrect voltage shifts	0 mV / °C
Tail Current / Charge End Current	Defines charge completion	2 % of C
Dynamic Cut-off / Protection	Avoids deep discharge under load	Enabled (ESS)
Max Charge Current	Limits BMS and inverter stress	300A
Max Discharge Current	Limits output & BMS protection	300A
Over-Voltage Alarm	Prevents over-charge	58.0 V
Under-Voltage Alarm	Early warning before cut-off	46.4 V

Product Packing List

Name	Quantity	Image
32kWh Battery	1 PCS	
1.5m Power cable 95mm ² (M8)	2 PCS	
1.8m Computer connection cable	1 PCS	
1.5m Communication cable	1 PCS	
Manual	1 PCS	

Functionality

Battery Voltage Calculation:

Voltage Sampling: The battery's voltage is measured with a deviation of $\pm 20\text{mV}$ over a 32-sample battery test.

Temperature Sensors:

The system has 2 temperature sensors monitoring the battery temperature.

- 1 sensor for ambient (surrounding) temperature.
- 1 sensor for the temperature of the MOS (Metal-Oxide-Semiconductor) components. Temperature
- Deviation: The deviation in temperature readings is $\pm 2^\circ\text{C}$.

Battery Capacity and Cycle Count:

Capacity Calibration: To determine the actual battery capacity, a full charge/discharge cycle is completed.

Remaining Capacity Estimation: The system estimates the remaining capacity with a deviation of $\pm 5\%$.

Communication Interface:

Monitoring and Control: Use a PC to monitor the battery pack, control operations, and adjust settings remotely.

Historical Data Recording and Management:

Data Recording: When abnormalities arise, the status and alarm information are recorded and saved. Fault

Data: The system can store up to 500 historical fault records.

Battery Management System (BMS) Parameter Settings:

The BMS allows the configuration of various parameters, including:

- Battery overvoltage/undervoltage
- Total battery voltage overvoltage/undervoltage
- Charge/discharge overcurrent
- Battery high/low temperature thresholds
- Battery capacity
- Operational mode
- Charge/discharge limit currents.

These settings can be adjusted within the battery monitoring system.

Multiple Protection Functions:

The battery has several protective features to prevent damage, including:

- Hardware protection
- Battery protection
- High/low temperature protection
- Output short-circuit protection

Dimensions

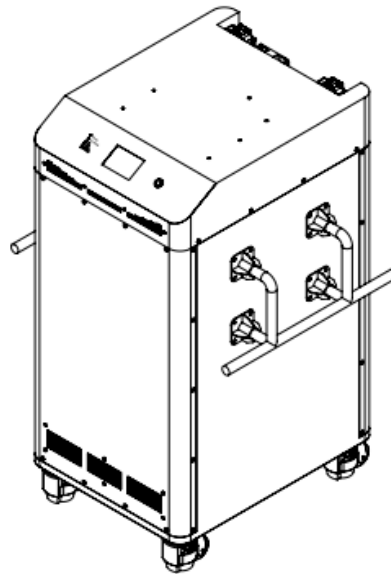
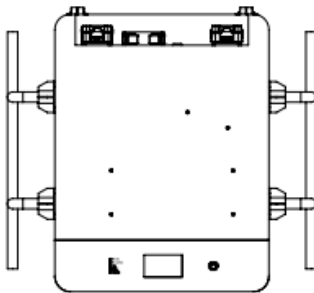
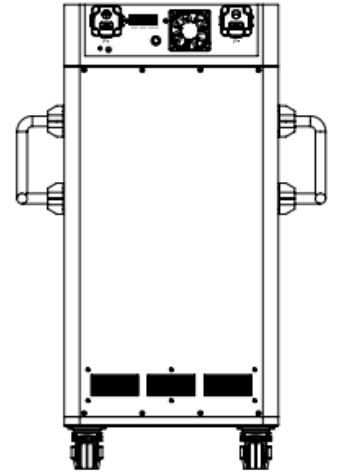
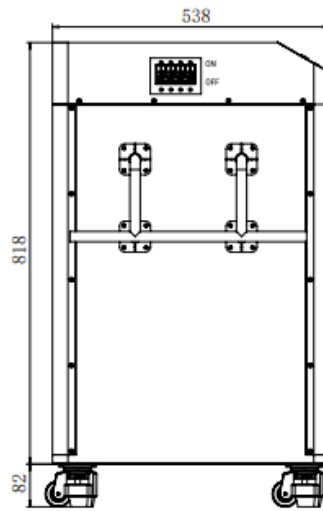
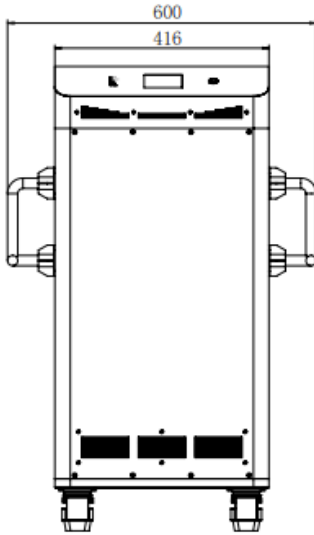

Installation Instructions

Choose a suitable installation location

- Do not place batteries on flammable building materials
- The temperature should be between 10°C and 30°C to maintain optimal operation.
- It is recommended to place the battery on a level surface.
- There should be some free space around the battery to dissipate heat (as shown in the figure below)

Suitable for placement on concrete or other non-flammable surfaces

- In special environments, the heat dissipation space (battery spacing) can be appropriately adjusted.



Communication Description

Communication

Matching inverter communication

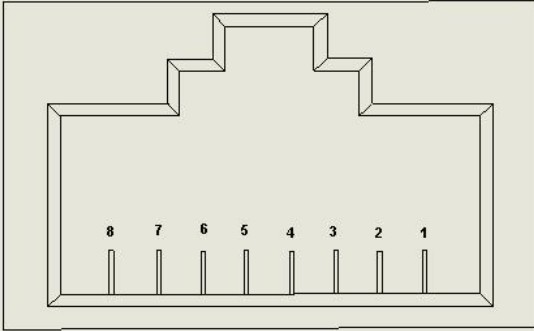
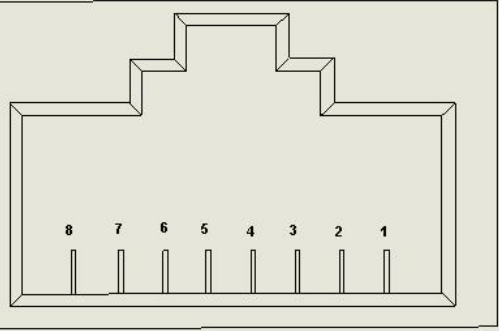
RS485A		RS485B	
			
RS485A		RS485B	
Pin	Definition description	Pin	Definition description
1、8	RS485-B	1、8	RS485-B
2、7	RS485-A	2、7	RS485-A
3	Master flag enable	3	GND
4	Autocode address 2	4	Autocode address 1
5	GND	5	GND
6	GND	6	Salve flag enable

The BMS communication interface is defined according to each inverter communication interface . The definition of the special inverter communication port is inconsistent with the BMS communication port definition, so you need to make your own network cable. If you use a regular network cable, the BMS may automatically start or fail to shut down. Generally, you can use a regular network cable for communication.

CAN/RS485

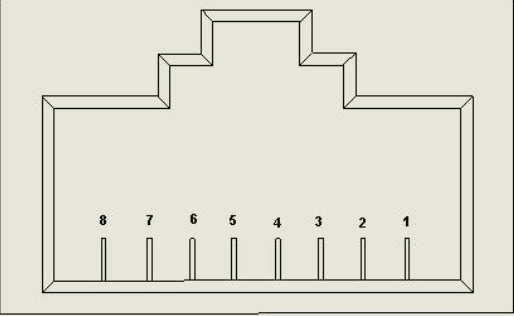

CAN/RS485	
Pin	Definition description
1, 8	RS485-B
2, 7	RS485-A
4	CAN-H
5	CAN-L
3, 6	GND

Internal Communications

Select the corresponding port for BMS internal communication and 19200 baud rate

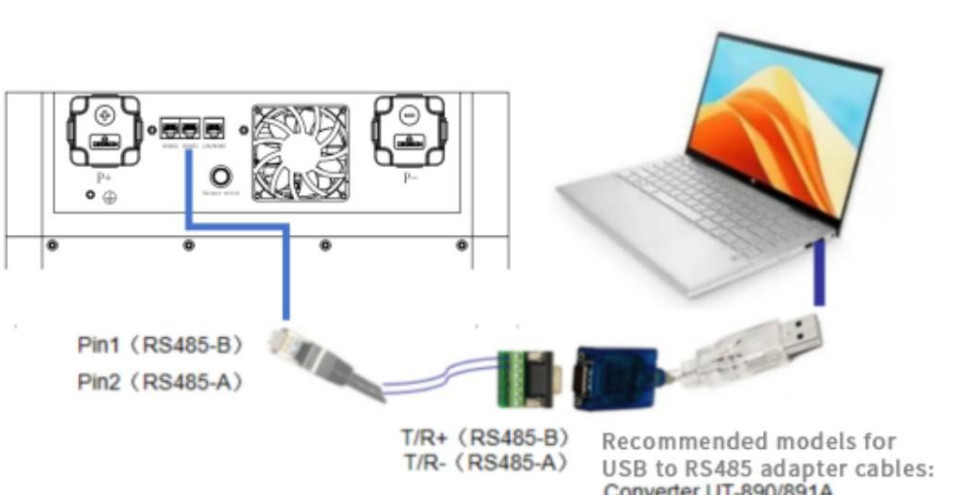

Pin1 (RS485-B)
Pin2 (RS485-A)

T/R+ (RS485-B)
T/R- (RS485-A)

Recommended models for USB to RS485 adapter cables: Converter UT-890/891A

Basic working modes

Charging Mode

When the BMS detects that the charger is connected and the external charging voltage is greater than the internal battery voltage by more than 0.5V, it turns on the charging MOSFET for charging. When the charging current reaches the effective charging current, it enters the charging mode. In the charging mode, both the charging and discharging MOSFETs are closed.

Discharge Mode

The BMS enters the discharge mode when it detects that the load is connected and the discharge current reaches the effective discharge current.

Standby Mode

When neither of the above two modes is satisfied, it enters the standby mode.

Shutdown Mode

The BMS enters shutdown mode after 48 hours of normal standby, battery undervoltage protection, key shutdown or external switch shutdown.

Wake-up conditions from shutdown mode:

1. Charging activation;
2. 48V voltage activation;
3. Press button to turn on.

LED light indication

LED light sequence

1 running light, 1 warning light, 4 capacity indicator lights

Capacity indication

state		Charge				Discharge			
Capacity indicator light		L4	L3	L2	L1	L4	L3	L2	L1
	0~25%	OFF	OFF	OFF	Flash	OFF	OFF	OFF	Always on
	25~50%	OFF	OFF	Flash	Always on	OFF	OFF	Always on	Always on
	50~75%	OFF	Flash	Always on	Always on	OFF	Always on	Always on	Always on
	≥75%	Flash	Always on	Always on	Always on	Always on	Always on	Always on	Always on
Running indicator light		always on				Flash			

Flashing instructions

Flashing mode	Bright	off
Flash 1	0.25s	3.75s
Flash 2	0.5s	0.5s
Flash 3	0.5s	1.5s

Battery protection parameters

Function Name	Function settings	Project List	Setting Value	Setting Range
Single cell voltage alarm	Enabled	Single high voltage alarm	3500 mV	Single-cell high-voltage recovery~Single-cell overvoltage protection
		Single high voltage recovery	3400 mV	3370mV~ Single high voltage
	Enabled	Single cell low voltage alarm	2900 mV	Single cell undervoltage protection~ Single cell low voltage recovery
		Single low pressure recovery	3100 mV	Single cell low voltage alarm ~ 3100mV
Single overvoltage protection	Enabled	Single overvoltage protection	3650 mV	Single high voltage alarm ~ 3850mV
		Single overvoltage recovery	3400 mV	Single high voltage recovery ~ single overvoltage voltage
		Overvoltage recovery conditions	1. The single cell voltage drops to the overvoltage recovery point 2. The remaining capacity is lower than 96% of the intermittent charging capacity Two conditions must be met to restore	
		The battery discharge current is detected to be $\geq 1A$		

Single cell undervoltage protection	Enabled	Undervoltage protection voltage	2700 mV	2 500mV~ Single cell undervoltage recovery
		Undervoltage recovery voltage	31 00 mV	Single cell undervoltage protection ~ Single cell low voltage alarm
		Single unit undervoltage shutdown	After undervoltage protection, shut down and maintain communication for 1 minute	
		Undervoltage recovery conditions	Charging current detected ($\geq 1A$)	
Battery total pressure alarm	Enabled	Total high voltage alarm	56.0 V	Total pressure high pressure recovery ~ total pressure overpressure protection
		Total high voltage recovery	54.0 V	51.0 V ~Total high voltage
	Enabled	Total low voltage alarm	46.4 V	Total voltage undervoltage protection~total voltage low voltage recovery
		Total low voltage recovery	48.0V	Total voltage low voltage warning ~ 49.0 V

Total pressure overvoltage protection	Enabled	Total overvoltage protection	57.6 V	Total voltage high voltage alarm ~ 58.0 V
		Total overpressure recovery	54.0 V	Total pressure high voltage recovery ~ total pressure overvoltage voltage
		Overvoltage recovery conditions	1. The single cell voltage drops to the overvoltage recovery point 2. The remaining capacity is lower than 96% of the intermittent charging capacity Two conditions must be met to restore	
			The battery discharge current is detected to be $\geq 1A$	
Total voltage undervoltage protection	Enabled	Total voltage undervoltage protection	43.2 V	40.0 V ~ Total voltage undervoltage recovery
		Total voltage undervoltage recovery	48.0 V	Total voltage undervoltage protection ~ total voltage low voltage alarm
		Total voltage undervoltage shutdown	After undervoltage protection, shut down and maintain communication for 1 minute	
		Undervoltage recovery conditions	Charging current detected ($\geq 1A$)	

Battery temperature prohibits charging	Enabled	Charging high temperature warning	50 °C	Charging high temperature recovery ~ charging over-temperature protection
		Charging high temperature recovery	47 °C	40 °C ~ Charging high temperature warning
		Charging over-temperature protection	55 °C	Charge over temperature recovery ~ 65 °C
		Charging over temperature recovery	50 °C	Charging high temperature recovery ~ charging over-temperature protection
		Charging low temperature warning	2 °C	Charging under-temperature protection ~ charging low temperature recovery
		Charging low temperature recovery	5 °C	Charging low temperature warning ~ 10 °C
		Charging under-temperature protection	-10 °C	- 15 °C ~ Charging under-temperature recovery
		Charging under-temperature recovery	0 °C	Charging under-temperature protection ~ charging low temperature recovery

Battery core temperature is prohibited	Enabled	Discharge high temperature alarm	55 °C	Discharge high temperature recovery ~ discharge over-temperature protection
		Discharge high temperature recovery	50 °C	45 °C ~ Discharge high temperature alarm
		Discharge over temperature protection	60 °C	Discharge over temperature recovery ~ 65 °C
		Discharge over temperature recovery	55 °C	Discharge high temperature recovery ~ discharge over-temperature protection
		Discharge low temperature alarm	-10 °C	Discharge under-temperature protection ~ discharge low-temperature recovery
		Discharge low temperature recovery	3 °C	Discharge low temperature alarm ~10°C
		Discharge under-temperature protection	-15 °C	-15 °C ~ Discharge under-temperature recovery
		Discharge under-temperature recovery	0 °C	Discharge under-temperature protection ~ discharge low-temperature recovery
Ambient temperature protection	Enabled	Ambient high temperature alarm	50 °C	Ambient high temperature recovery ~ Ambient over-temperature protection

		Environmental high temperature recovery	47 °C	45 °C ~ Ambient high temperature alarm
		Ambient over temperature protection	60 °C	Ambient over temperature recovery ~ 65 °C
		Ambient over temperature recovery	55 °C	Environmental high temperature recovery ~ Ambient over temperature protection
		Low ambient temperature alarm	0 °C	Ambient undertemperature protection Low temperature recovery
		Low temperature recovery	3 °C	Low ambient temperature alarm ~ 10 °C
		Ambient undertemperature protection	-10°C	-15 °C ~ Ambient undertemperature recovery
		Ambient undertemperature recovery	0°C	Ambient undertemperature protection ~ Ambient low-temperature recovery

Power temperature protection	Enabled	Power high temperature alarm	95 °C	Power high temperature recovery ~ power over temperature protection
		Power high temperature recovery	85 °C	45 °C ~Power high temperature warning
		Power over temperature protection	110 °C	Power high temperature alarm ~110 °C
		Power over temperature recovery	85 °C	Power high temperature recovery ~ power over temperature protection
Charging current limit	Disabled	Active current limiting	10A	When the charger current is greater than 10A, turn on current limiting
	Enabled	Passive current limiting	305A	The charger current is greater than the charging overcurrent alarm (the value can be set), and the current limit is turned on
		Charging current limit delay	5 minutes	After the current limit is turned on, recheck whether the current limit is turned on after 5 minutes

Charging overcurrent alarm	Enabled	Charging overcurrent alarm	305 A	Charge overcurrent recovery ~ Charge overcurrent protection
		Charge overcurrent recovery	303 A	0A~ Charging overcurrent alarm
Charging overcurrent protection	Enabled	Charging overcurrent protection	3 10A	0A ~ 150A
		Charge overcurrent delay	10 S	Can be set
		Overcurrent recovery conditions	Discharge is restored immediately, or automatically after 60 seconds	
Effective charging current	Charging current		500mA	
	Charge exit current		400mA	
Discharge overcurrent alarm	Enabled	Discharge overcurrent alarm	-305 A	Discharge overcurrent protection ~ discharge overcurrent recovery
		To overcurrent recovery	- 3 03A	Discharge overcurrent alarm ~0A

Discharge overcurrent protection	Enabled	Discharge overcurrent protection	- 3 10A	Transient overcurrent protection ~0A	
		Discharge overcurrent delay	10 S	Can be set	
		Overcurrent recovery conditions	Charging resumes immediately or automatically after 60 seconds		
Transient overcurrent protection	Enabled	Transient overcurrent protection	- 5 00A	Discharge overcurrent protection value to 5 00A	
		Transient overcurrent delay	3 0 0 mS	Can be set	
		Transient overcurrent recovery	Charging resumes immediately or automatically after 60 seconds		
	Disabled	Transient overcurrent lockout	Continuous secondary overcurrent, exceeding the overcurrent lock times		
		Overcurrent lock times	5 times		
		Momentary lock release	Connect the charger		

Output short circuit protection	Enabled (Currently does not support the shutdown setting)	Short circuit protection current and delay	(not configurable) Write program
		Short circuit protection recovery	Charging resumes immediately or automatically after 60 seconds
	Enabled	Short circuit protection lock	Continuous output short circuit, exceeding the overcurrent lock times
		Short circuit lock times	5 times
		Short circuit lock release	Connect the charger
Effective discharge current	Discharge entry current		500mA
	Discharge exit current		400mA

Cell balancing function	Enabled	Standby Balance	No charge and discharge state, start balancing		
		Standby balance time	10 hours	Can be set	
	Enabled	Charge equalization	Enable balancing in charging and floating charging states		
	Turn on voltage condition	Balanced start voltage	3450 mV	Can be set	
		Balanced opening pressure difference	50 mV		
		Equalization end pressure difference	30mV		
	Enabled	Balanced temperature limit	Balanced shutdown temperature range according to (ambient alarm temperature determination)		
		Balanced high temperature prohibition	50 °C	Can be set	
		Balanced low temperature prohibition	0 °C		
	Battery alarm failure	Enabled	Cell failure voltage difference	150mV	Can be set
Cell recovery voltage difference			100mV		

Battery capacity setting	Battery rated capacity		628Ah	5Ah to 628Ah
	Remaining battery capacity		Estimated based on cell voltage	Can be set
	Cycle cumulative capacity		20%	Number of cycles (adjustable)
	Enabled	Remaining capacity warning	10 %	

	Enabled	Remaining capacity protection	2 %	Turning output off
Reset button	Power on/activation		The BMS is in sleep mode. Press the reset button for 1 second, the BMS is activated, and the LED indicators light up in sequence, and then it enters normal working mode.	
	Shutdown/Hibernation		When the BMS is in standby or working state (except charging), press the reset button for 3S, the BMS will be put into sleep mode, and the LED indicators will light up in sequence, and then enter the sleep mode;	

Pre-charge function	2000ms	0~5000ms can be set	BMS starts pre-charging function instantly	
BMS power management	Enabled	Maximum standby time	48h (charger is not present and there is no effective discharge current)	
Low temperature heating of battery cells	Enabled	Low temperature heating of battery cells	0°C	Can be set
		Cell heating recovery	10°C	
		Heating start logic	When the charger is online and the battery cell temperature reaches the start-up condition, heating is turned on. No heating is performed in standby and discharge states.	
External switch	Enabled	When the BMS is in standby mode, the external switch can be operated to turn the BMS off and on		
LCD screen	Enabled	Simplified monitoring software to view data such as battery cells, temperature, current, etc.		
Manual charging activation	Enabled	1 minute	After undervoltage protection, the BMS shuts down. Press the button manually to activate and clear the undervoltage protection to force output.	Can be set

Compensation impedance	Connected fault impedance	10m Ω	Default is between 8 and 9	Battery connection line impedance compensation
	Compensation point 1	0m Ω	9	Can be set
	Compensation point 2	0m Ω	13	

Packaging

Packed in a dry, dust and moisture proof packaging box. Pack the product in plastic film/EPE and pack in wooden box.

Specifications: L 92cm*W 66cm*H 106cm Packing quantity 1 unit Weight: 280kg



Getting in touch

Should you encounter a problem with your NKON ESS Pro unit it is important you contact our Customer Services team first and foremost. This gives us an opportunity to help you resolve the issue before any problems arise. By coming directly to us, before posting on forums or groups, we can help you resolve any issues or concerns quickly and efficiently.

Please send any images or screenshots, along with a description of your issue to cs@nkon.nl. If your issue is urgent and you need to talk with a member of the tech team immediately, please call +31403690600.