

# AMBEROCK

Power Supply (Power Station)

SR2000/SR2000-AC  
SR5000/SR5000-AC

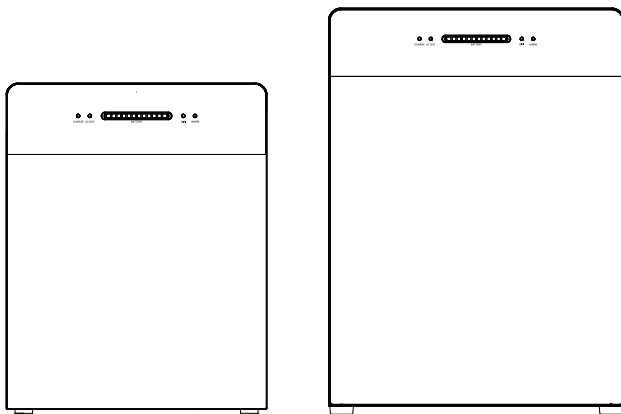

User Manual



# Legal Notice

---

©2025 Shanghai Voltdeer Technology Co., Ltd. All rights reserved.

Without the prior written consent of Shanghai Voltdeer Technology Co., Ltd., it is prohibited to copy or distribute this manual or any part thereof in any manner, or upload this manual to third-party platforms such as public networks in any way.

## Disclaimer

This manual is intended to guide the installation, use and maintenance of this product. Before using this product, please read this manual completely and keep it properly.

The pictures, diagrams, interfaces and parameters herein are for illustrative purposes only. Please refer to the actual product and official announcements for specific details. Shanghai Voltdeer Technology Co., Ltd. (hereinafter referred to as "the Company") reserves the right to update or modify the manual content, product specifications and functions without prior notice.

Failure to install and use in accordance with this manual or applicable laws and regulations may result in personal injury, property damage or warranty invalidation.

The relevant risks and consequences shall be borne by the user. Please only use accessories, consumables and services approved by the Company. Do not modify or disassemble the product without authorization.

Shanghai Voltdeer Technology Co., Ltd. makes no express or implied representations or warranties regarding all information in this manual.

If any clause of this manual conflicts with applicable laws and regulations, the laws and regulations shall prevail. Such conflict shall not affect the validity and enforceability of the remaining clauses. Some disclaimer clauses may not apply in certain countries and regions, and in such cases, the relevant clauses shall apply to the maximum extent permitted by local laws and regulations.

The final interpretation right of this manual belongs to Shanghai Voltdeer Technology Co., Ltd.

# Safety Precautions

---



## Warning

1. Read this document and other relevant product documents before operation.
2. The installation of this product must comply with all applicable local laws, regulations or standards.
3. An overcurrent circuit breaker must be installed between this product and the power grid.
4. When the photovoltaic (PV) array is illuminated, the inverter can be connected to the grid, used off-grid or charge the battery.
5. During installation and maintenance, use insulated tools and wear personal protective equipment.
6. Install this product in a clean, dry and well-ventilated environment.
7. Place this product out of the reach of children and pets. If the product is used near children, it must be under close supervision.
8. The connection length of each PV cable used in this product shall be less than 3 meters.
9. Before making any electrical connections, ensure that all loads (such as equipment powered by this product) are disconnected from the power supply.
10. When disconnecting the product, pull the plug instead of the power cord to reduce the risk of damage to the plug and cable.
11. Do not insert fingers or hands into the product.
12. Do not expose this product directly to sunlight, rain or snow.
13. Do not expose this product to strong electromagnetic fields to prevent radio interference.
14. Do not install or operate this product near sources of flammable, explosive, corrosive or corrosive substances.
15. Do not install or operate this product under extreme weather conditions such as lightning, heavy rain or strong winds.
16. Do not subject this product to severe impact, vibration or dropping to avoid physical damage.
17. Do not drag, squeeze, step on this product or throw it into fire, otherwise there is a risk of explosion.

## Safety Precautions

---

18. Do not use damaged wires or cables for this product.
19. Do not damage, deface or remove any identification labels on this product.
20. Do not disassemble, repair or modify this product by yourself. For any maintenance or repair services, please contact Voltdeer customer service.
21. Do not place this equipment near open flames, heat sources or flammable materials.
22. Do not shake this equipment.
23. Do not use the equipment if the outer casing is severely damaged.
24. Do not disassemble this equipment.
25. Placing the battery in a high-temperature environment may cause explosion or leakage of flammable liquids/gases. Batteries in extremely low air pressure environments may also cause explosion or leakage of flammable substances.
26. Do not disassemble or damage the battery. The released electrolyte is toxic and harmful to the skin and eyes.
27. Do not use any non-official or unapproved components and accessories. For replacement, please contact Voltdeer for further assistance.
28. Do not clean this product with flammable or toxic solvents. Use a dry soft cloth for wiping.
29. Do not place heavy objects (> 40Kg) on this product.
30. Equipment disassembly: For safe disassembly of this product, please perform the following steps in sequence:
  - a. Power off the connected loads.
  - b. Remove the cables from the PV terminals.
  - c. Disconnect the cable from the AC socket.
  - d. Disconnect the cable from the mains terminal.
  - e. Turn off the product.
31. Grounding instructions: This product must be grounded. In case of failure or breakdown, grounding provides a path with minimal resistance for current to reduce the risk of electric shock.

# Safety Precautions

---

For your safety, the grid-connected wiring harness standard-equipped by Voltdeer contains a ground wire inside. The user must ensure that the ground wire of the wall socket is connected to the earth, and the plug must be correctly installed in a grounded socket in accordance with local specifications.

The plug must be correctly installed in a grounded socket in compliance with all local codes and regulations.

Improper connection of the equipment's grounding conductor may pose an electric shock hazard.

In the following cases, consult a qualified electrician and do not replace the plug provided with the product at will:

- Uncertain whether the product is correctly grounded;
- You find that the plug provided with the product does not match the socket.

32. External grounding instructions: If the wall socket has no ground wire, the product's grounding screw must be connected to the earth.

In installation locations with insufficient grounding or special grounding requirements specified by local regulations, supplementary grounding may be required. In such cases, use the product's grounding terminal to establish a good ground connection.

33. Personnel requirements: Certain installation or maintenance tasks must be performed exclusively by qualified technical personnel. Refer to the personnel requirements emphasized in the product documentation to ensure these tasks are completed correctly and safely.







Attention

## Useage

Symbol	Description	
	User Manual	Before installation, operation, and maintenance, please carefully read the user manual and all safety instructions.
	Warning!	Disconnect the equipment from all voltage sources before maintenance.

# Safety Precautions

Symbol	Description	
	Warning! Electric Shock Hazard (Maintenance)	There are no user-serviceable parts inside. Please entrust maintenance to qualified personnel.
	Warning! Burn Hazard	Do not touch the casing during equipment operation.
	Warning! Electric Shock Risk	Wait at least 15 minutes after all power supplies are disconnected before performing maintenance.
	CE Marking	This equipment complies with the essential requirements of EU regulations.
	Waste Electrical and Electronic Equipment (WEEE) Directive	Do not dispose of this equipment as household waste. Please comply with local requirements for the disposal of electronic waste.

- It is not recommended to use this equipment to power safety-related personal medical devices.
- Ensure good ventilation when using the equipment.
- Do not move or invert the equipment during use. Place the equipment correctly.
- Do not stack heavy objects on the equipment.
- For safety, only use accessories (cables, PV panels, etc.) provided or recommended by Voltdeer. Voltdeer is not responsible for damage caused by third-party equipment.
- Battery maintenance shall be performed or supervised by personnel familiar with batteries.
- The casing has an IP65 rating.

## Transportation

- Do not carry the equipment on an airplane.

## Maintenance

- Charge the equipment once every 3 months. For long-term storage, maintain the power level between 40% and 70% before storage. If the equipment is completely discharged, charge it within 12 hours. Prolonged power outage may cause irreversible damage to the equipment.
- If the equipment fails to operate normally, please contact the supplier or the nearest service center.

# Safety Precautions

---

- Do not disassemble the equipment for maintenance or repair by yourself.
- To maintain the long-term optimal performance of the equipment, it is recommended to perform the following inspections at least every quarter:
  1. Ensure unobstructed air flow around the inverter and remove dirt and debris from the heat dissipation vents.
  2. Inspect all exposed wires for insulation damage caused by sun exposure, friction with surrounding objects, aging and brittleness, or gnawing by insects and rodents. Repair or replace the wires if necessary.
  3. Confirm that the indicator light display is consistent with the equipment operation status. Pay attention to all fault or error messages and take corrective actions if necessary.
  4. Inspect all wiring terminals for signs of corrosion, insulation damage, high temperature or ablation/discoloration, and tighten the terminals.
  5. Check the equipment for dust accumulation, insect nesting and corrosion. Clean as needed and regularly clean the mosquito net.
  6. If the surge arrester fails, replace the faulty surge arrester in a timely manner to prevent the inverter and other user equipment from being damaged by lightning strikes.

Note: Before performing any inspection or operation, ensure that the equipment is disconnected from all power connections. Wait 15 seconds after power-off to avoid electric shock risk.

The Company shall not be liable for damages caused by the following reasons:

- a) Damages caused by improper use or use in incorrect locations.
- b) Damages caused by the open-circuit voltage of PV modules exceeding the maximum allowable voltage.
- c) Damages caused by operating temperature exceeding the specified operating temperature range.
- d) Damages caused by disassembly and repair of the equipment by unauthorized personnel.
- e) Damages caused by force majeure: Damages incurred during transportation or handling of the equipment.

# Safety Precautions

---

## Cleaning

- Clean the external surface of the equipment with a soft dry cloth.

## Disposal

- Dispose of waste batteries in accordance with national or regional laws or regulations.

# Table of Contents

---

1 Packing List .....	1
2 Interface Description .....	1
3 Product Introduction .....	2
4 Indicator Light Description .....	3
5 Tools Required.....	4
6 Installation Environment Requirements .....	4
7 Operating Instructions.....	5
8 Fault Codes and Corresponding Measures .....	7
9 Specification List.....	10
10 APP.....	13
11 Frequently Asked Questions (FAQs).....	23

# 1 Packing List

---

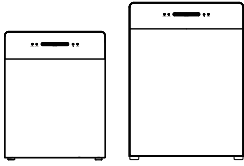

SR2000/SR2000-AC  
/SR5000/SR5000-AC

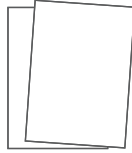

User Manual



Grid-Connected Power Line

# 2 Interface Description

---

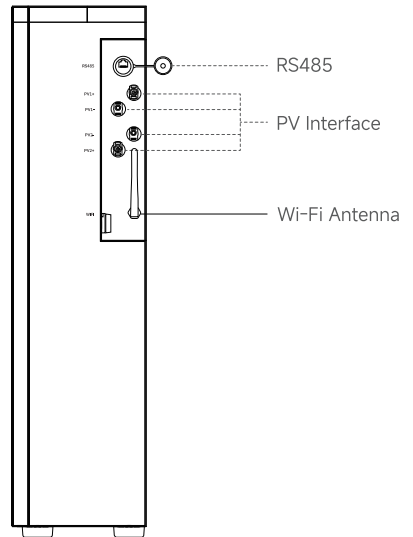
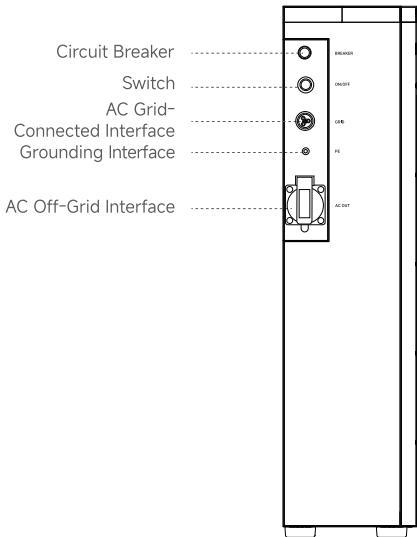

# 3 Product Introduction

The energy storage system with two working modes: AI automatic mode and manual mode. This system can charge at low peaks and feed power back at high peaks, there by saving electricity for households while also providing a stable power supply.

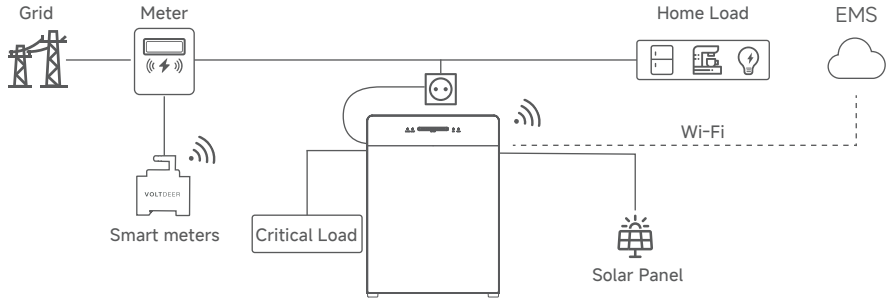

The product is compatible with all photovoltaic systems. Here are some home application scenarios when combined with solar energy systems.

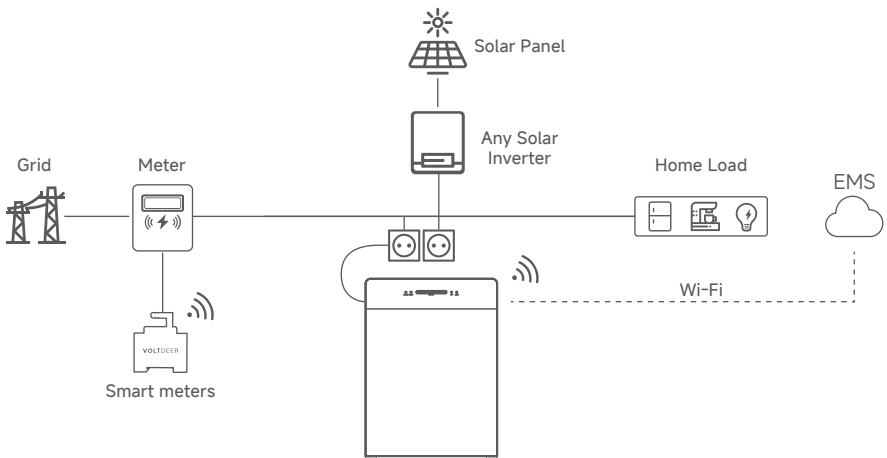

# 4 Indicator Light Description

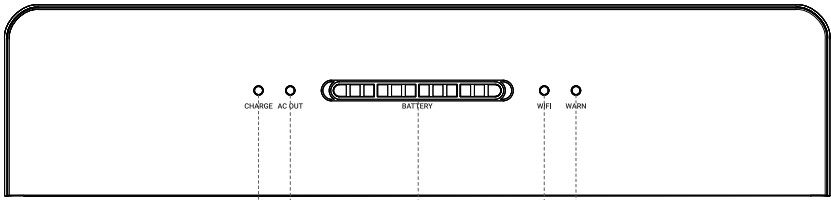













Charging Status Indicator Light      Off-grid Outout Indicator light      Battery Power Indicator Light      Wi-Fi Indicator Light      Fault Indicator Light

Indicator Light	Color	Description
CHARGE	Ice blue	Flashing: Fast charging in progress
		Steady on: Battery fully charged
AC OUT	Ice blue	Steady on: Mains bypass output in progress
		Flashing: Inverter off-grid output in progress
BATTERY	Ice blue	0%: All energy bars off
		0% < SOC ≤ 25%: 25% energy bar lit
		25% < SOC ≤ 50%: 50% energy bar lit
		50% < SOC ≤ 75%: 75% energy bar lit
Wi-Fi	Ice blue	Steady on: Network configuration successful
		Flashing: Unconfigured or reset state
WARN	Red	Steady on: Fault

## 5 Tools Required

---

Screwdriver		Multimeter	
Wrench		Tape measure	
Diagonal pliers		Cable ties	
Insulated gloves		Insulated shoes	
Utility knife		Goggles	
Wire stripper		Marker pen	

## 6 Installation Environment Requirements

---

To meet heat dissipation and safety isolation requirements, when installing the equipment, a minimum space of 150mm must be reserved between the top and rear of the equipment and the nearest obstacle.

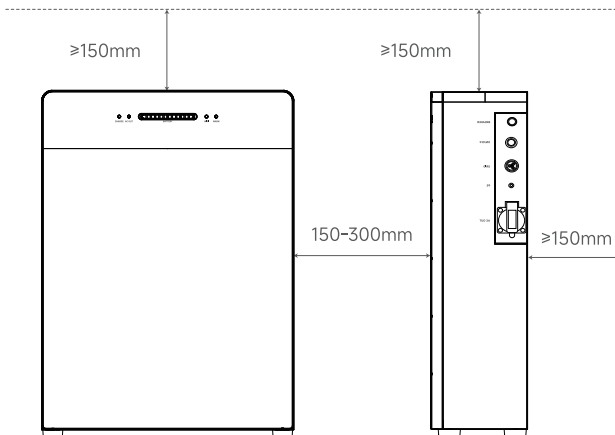

# 7 Operating Instructions

---

## 7.1 Grid Connection

Connect the grid connection harness to the energy storage device, insert the AC power plug into the socket, and connect it to the local power grid.

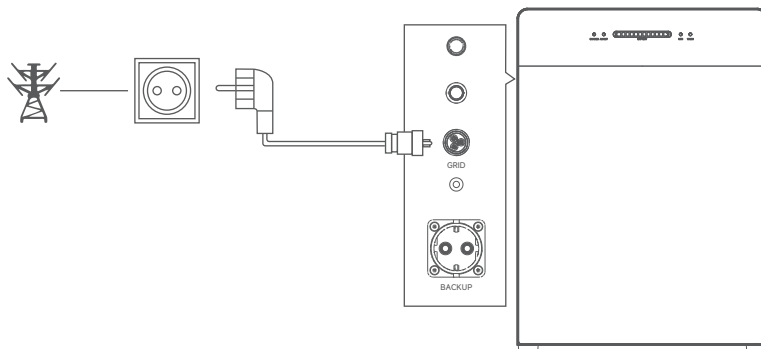

## 7.2 OFF Grid Connection

Connect the power device to the BACKUP port of this product. The maximum supported power is 2400W.

- ① With Energy saving mode enabled, the BACKUP output power will be less than 25W for 5 minutes, at which point the BACKUP will turn off.
- ② With Energy saving mode disabled, the BACKUP will continue to operate.

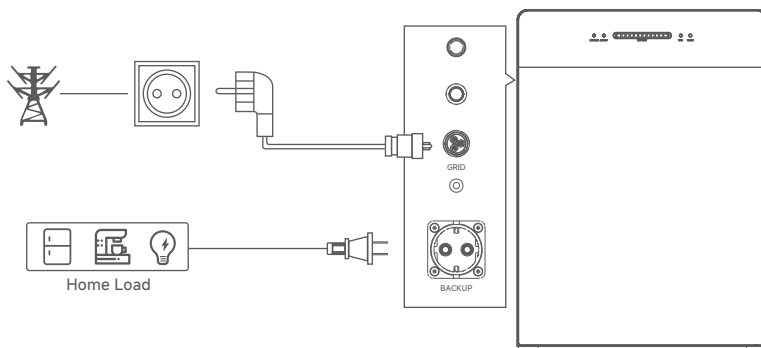

# 7 Operating Instructions

---

## 7.3 ON/OFF Switch

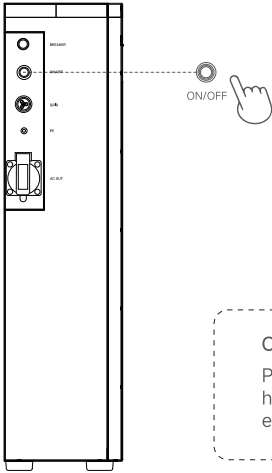

### ON/OFF Switch:

Press the self-locking switch button. The equipment turns on after hearing a "click" sound. Press the self-locking switch button again. The equipment turns off after hearing a "click" sound.

Note: After pressing the power-off button, wait at least 5 seconds before pressing the button again to turn on the equipment.

# 8 Fault Codes and Corresponding Measures

## 8.1 Fault Code

Fault code	Fault Name	Output Affected	Description
[1]	Low battery voltage alarm	Yes	Battery voltage is lower than the voltage alarm threshold. Battery discharge alarm is triggered, and output stops.
[2]	Battery EOD	Yes	Battery voltage is at low level. Battery discharge protection is activated, and output stops.
[3]	The average discharge current of the battery is too high protect	Yes	If the average discharge current of the battery is greater than the maximum input battery current for one minute, the output is turned off and the battery discharge protection stops.
[4]	Battery software overcurrent alarm	Yes	Current exceeds the software overcurrent alarm threshold. Battery overcurrent alarm is triggered, and output stops.
[5]	Battery open circuit	Yes	Mains is present, and the equipment is not turned on by pressing the button.
[6]	Battery overvoltage alarm	Yes	Battery voltage exceeds the set overvoltage threshold, and output stops.
[7]	Low battery capacity	No	Reminder for low battery capacity.
[8]	Low battery capacity shutdown	Yes	Battery capacity rate is low. Output stops, and the battery shuts down.
[9]	Bypass output overload	Yes	Mains bypass supplies power to the load. The load is overloaded, AC output is turned off, and mains charging stops.
[10]	Inverter output overload	Yes	The inverter is overloaded. AC output is turned off, and output stops.
[11]	Inverter AC output short circuit	Yes	Inverter AC output is short-circuited. AC output is turned off, and output stops.
[12]	Inverter hardware overcurrent alarm	Yes	Inverter AC output is overcurrent. AC output is turned off, and output stops.
[13]	Inverter DC component overload alarm	Yes	Abnormal regulation of the DC component of the inverter voltage. AC output is turned off, and output stops.
[14]	Bus software overvoltage	Yes	Internal battery boost. Software protection for bus voltage overvoltage is activated. AC output and charging are turned off.
[15]	Bus hardware overvoltage	Yes	Internal battery boost. Hardware protection for bus voltage overvoltage is activated. AC output and charging are turned off.
[16]	Bus undervoltage alarm	Yes	Internal battery boost. Bus voltage undervoltage protection is activated. AC output and charging are turned off.
[17]	Bus short circuit	Yes	Internal battery boost. Bus voltage short-circuit protection is activated. AC output and charging are turned off.
[18]	PV input overvoltage	Yes	Solar input voltage exceeds the maximum allowable input voltage. Solar charging is turned off.

# 8 Fault Codes and Corresponding Measures

[19]	PV current hardware overcurrent	No	Hardware protection for solar charging overcurrent is activated. Solar charging is turned off.
[20]	PV radiator over-temperature	No	The temperature of the solar charging radiator is too high. Solar charging is turned off.
[21]	Inverter radiator over-temperature	Yes	The temperature of the radiator for AC charging or battery inverter discharge is too high. AC charging or battery inverter discharge is turned off.
[22]	Transformer over-temperature	Yes	The temperature of the internal main transformer for AC charging or battery inverter discharge is too high. AC charging or battery inverter discharge is turned off.
[23]	Mains input relay short circuit	Yes	Short-circuit protection for the AC input relay to prevent reverse feeding of the inverter AC output to the bypass AC input.
[24]	Output relay short circuit	Yes	Short-circuit protection for the AC output relay. Inverter output and all charging functions are turned off.
[25]	Fan fault	Yes	Fan jamming or failure fault. Inverter output and charging are turned off.
[26]	BMS communication fault	Yes	Communication failure between the inverter and BMS. Inverter output and charging are turned off.
[27]	BMS abnormal alarm	Yes	Check the lithium battery BMS fault type and then clear the lithium battery fault.
[28]	BMS battery over-temperature	Yes	Cell temperature exceeds the BMS over-temperature threshold.
[29]	BMS battery overcurrent	Yes	Current exceeds the BMS overcurrent threshold.
[30]	BMS battery overvoltage	Yes	Cell voltage exceeds the BMS battery overvoltage threshold.
[31]	BMS battery undervoltage	Yes	Cell voltage is lower than the BMS battery undervoltage threshold.
[32]	BMS low battery temperature	Yes	Cell temperature is lower than the low-temperature threshold of the BMS.
[33]	Grid voltage overvoltage	Yes	Grid voltage exceeds the overvoltage threshold.
[34]	Grid voltage undervoltage	Yes	Grid voltage is lower than the undervoltage threshold.
[35]	Grid frequency over-frequency	Yes	Grid frequency exceeds the over-frequency threshold.
[36]	Grid frequency under-frequency	Yes	Grid frequency is lower than the under-frequency threshold.

# 8 Fault Codes and Corresponding Measures

## 8.2 Troubleshooting

Fault code	Fault	Troubleshooting Measures
/	Indicator light not illuminating	Check if the battery switch is turned on.
【1】 【2】	Battery undervoltage	Charge the battery or restore it to above the undervoltage recovery voltage.
【5】	Battery open circuit	Check if the power-on button is activated.
【6】	Battery overvoltage	If the battery voltage exceeds the protection threshold, discharge the battery or reduce the voltage to below the overvoltage recovery point.
【9】 【10】	Bypass output overload / Inverter output overload	① Reduce the number of electrical devices; ② Restart the all-in-one machine to resume load output.
【11】	Inverter AC output short circuit	① Carefully inspect the load connection and eliminate the short-circuit fault point; ② Re-power the device to resume load output.
【18】	PV input overvoltage	Use a multimeter to check if the PV input voltage exceeds the maximum allowable input voltage.
【21】 【22】	Inverter radiator over-temperature / Transformer over-temperature	Allow the device to cool down to below the over-temperature recovery temperature, and normal charging/discharging control will resume.
【25】	Fan failure	Check if the fan is not rotating or blocked by foreign objects.

Note: If the product fault cannot be resolved using the methods in the above table, please contact our after-sales service department for technical support. Do not disassemble the device by yourself.

# 9 Specification Sheet

Specification Type	SR2000	SR2000-AC	SR5000	SR5000-AC
<b>Battery Information</b>				
Rated Voltage	51.2V			
Battery capacity	2560Wh	2560Wh	5120Wh	5120Wh
Cycle life	>6000 (25°C)			
Cell type	LiFePO4			
Depth of discharge (DOD)	90%			
Capacity	50Ah	50Ah	100Ah	100Ah
<b>PV input</b>				
Rated voltage range	10-100Vdc	/	10-100Vdc	/
Maximum input voltage	100 Vdc	/	100 Vdc	/
Maximum input current	16A*2	/	16A*2	/
Maximum input power	1000W*2	/	1000W*2	/
<b>Mains Input</b>				
Rated power	2.4kW			
Grid connection type	L/N/PE			
Rated grid voltage	230Vac			
Grid voltage range	184-253Vac			
Rated grid frequency	50Hz			
Rated grid current	10.44A			
Power factor	>0.9			
Current harmonics	<3%			
<b>Grid-connected</b>				
Rated power	0.8kW (Rated) / 2.4kW (Maximum)			
Grid connection type	L/N/PE			
Rated grid voltage	230Vac			
Grid voltage range	184V-253Vac			
Rated grid frequency	50Hz			
Rated grid current	3.48A (Rated) / 10.9A (Maximum)			
Power factor	>0.9			
Current harmonics	<3%			

# 9 Specification Sheet

Specification Type	SR2000	SR2000-AC	SR5000	SR5000-AC
<b>Off-grid Output</b>				
Rated off-grid output power			2.4kW	
Rated output current			10.44A	
Rated output voltage			230Vac	
Rated output frequency			50HZ	
Voltage harmonics			<2%	
<b>Efficiency</b>				
Maximum inversion efficiency (battery to AC)			>93.5%	
<b>Protection</b>				
Protection level			I	
<b>General Parameters</b>				
Isolation type			Isolation	
Operating temperature range			-20°C ~+ 60°C	
Relative humidity			0-95%	
IP rating			IP65	
Cooling method			Intelligent cooling	
Altitude			2000m	
Grid-connected standards		EN 50549-1/10、C10/11、VDE 4105、CEI 0-21		
Regulations		IEC62109、IEC62477		
Electromagnetic compatibility (EMC)		IEC/EN 61000		
Dimensions (L*W*H)	446*180*568mm	446*180*568mm	520*181*715mm	520*181*715mm
Weight	36±2kg	36±2kg	59±2kg	59±2kg
Grid connection			Single-phase plug	
Display			LED indicator lights	
Communication method		Wi-Fi & Bluetooth & RS-485 (Waterproof Aviation Plug)		

Note 1: The rated voltage/frequency range can be modified according to the requirements of the local power department.

\* Enabling this function must comply with local regulations and be operated by professional technicians!

Note 2: Refer to local electrical regulations to determine the number of power sources that can be connected to each branch.

Note 3: The use of secondary lithium batteries and battery systems, especially misuse, may cause hazards and potential injuries.

Note 4: The product's maximum charging current is 60A, and the maximum discharging current is 60A; charging temperature range: 0°C-57°C, Discharging temperature range: -20°C-60°C; voltage range: 44.8V-58.4V. Use within the specified current, temperature, and voltage ranges to avoid injury.

# 9 Specification Sheet

## Dimension

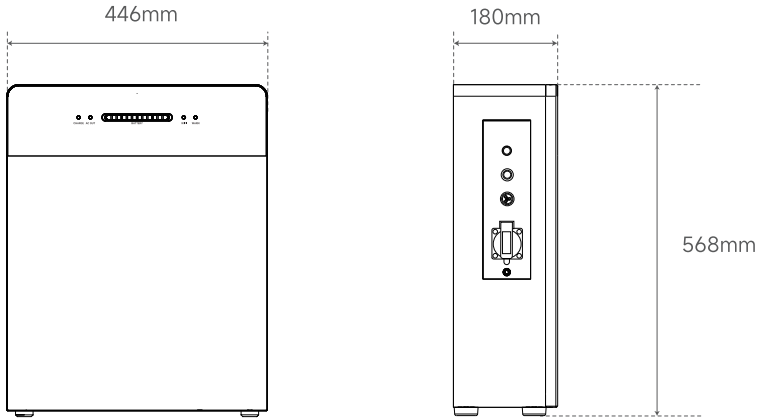

SR2000/SR2000-AC

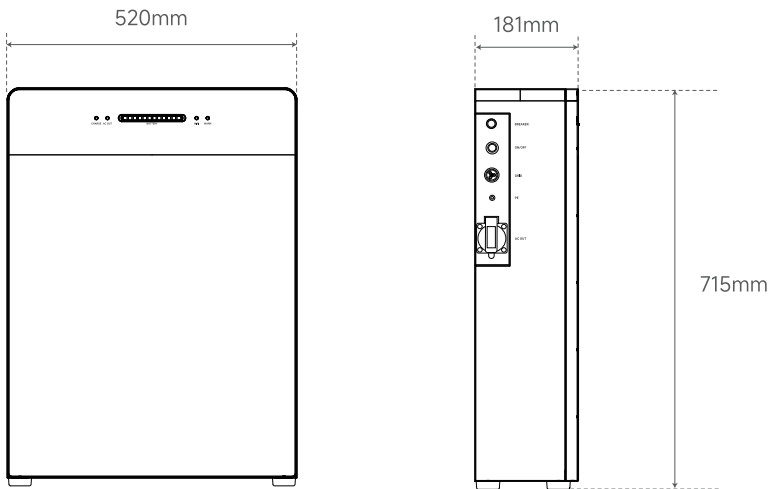

SR5000/SR5000-AC

## 10.1 Application download

You can search for "AMBERROCK" in the mobile app store to download the app, or scan the QR code below for download.



## 10.2 Registration

For first-time use of the smart app, you need to register an account first.

If you already have an AMBERROCK app account, log in directly with your account and password. Multi-language switching: The AMBERROCK app supports multiple languages, including Simplified Chinese, German, English, French, Dutch, and Italian. You can select and switch languages in the app as shown in the figure below. After logging in, you can also change the language at any time in the app's settings page.

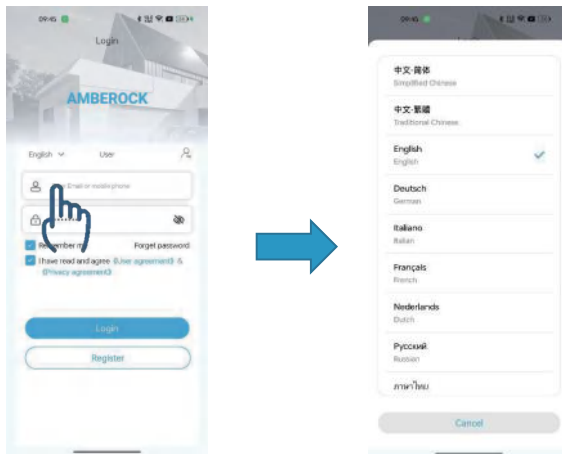

① Registration: Click the [Register] button to jump to the registration prompt. Fill in the required fields (marked with a red \*) in the correct format to complete account registration.

Step 1: Access the registration page.

Click the " Register " button on the login page to enter the registration page.

# 10 APP

Step 2: Complete the registration process as prompted.

Enter your email address, input the correct email account as prompted, and verify it. The smart app supports email-based account registration.

After successful verification, check the checkbox in the agreement section to indicate that you agree to the "User agreement" and "Privacy agreement".

Step 3: Successful registration and login.

After completing the account information, you will be redirected to the login page. Enter the newly registered account and password to log in.

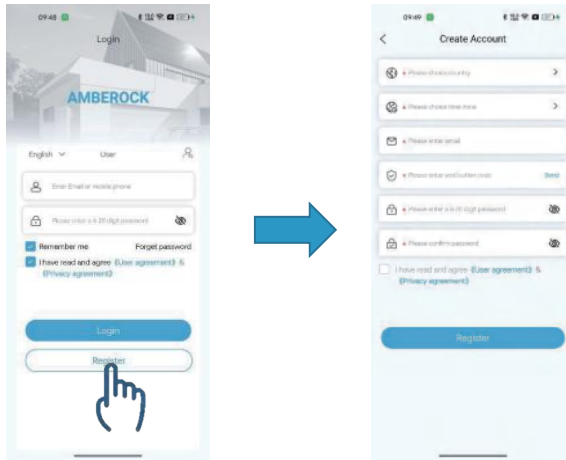

② Password retrieval: Click the [Forget password] button to jump to the password retrieval page. Select "Find email" and enter the required information as prompted.

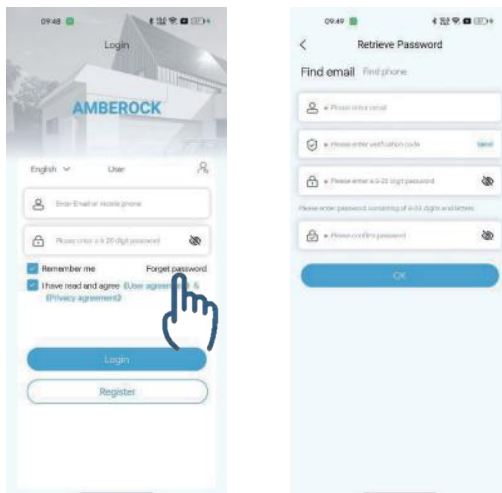

# 10 APP

## 10.3 Login

After completing account registration, log in by entering your account and password, then click the [Login] button to access the app.

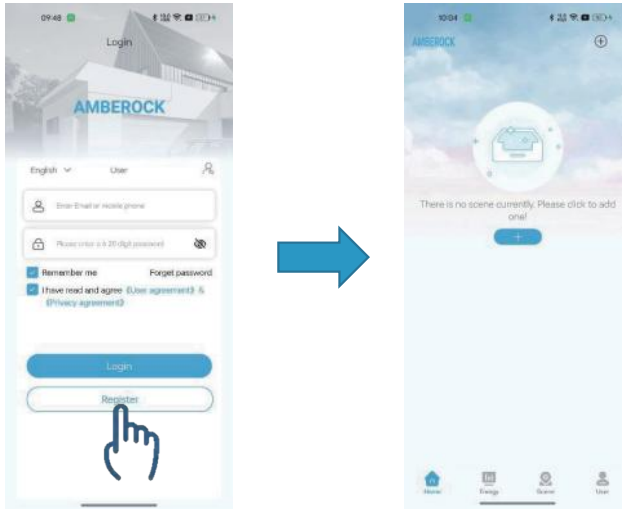

## 10.4 Add scene

1. After entering the app for the first time, click the [+] button in the center of the screen to create your first scene; or click the [Devices] tab below and then click the [+] button in the upper right corner to add a scene.
2. Click the [+] button in the upper right corner to add a device, or click the [Devices] tab below to view and manage all devices.
3. Fill in the power station information as prompted and click "Save" to successfully add the power station.

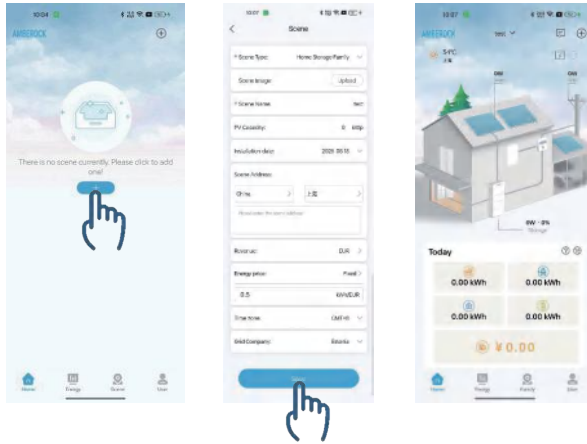

## 10.5 Add device

### 10.5.1 Add device and connect to Wi-Fi network

Power on the device and ensure it is functioning properly.

1. Select the scene where the device is located as the current scene.
2. Click the add button in the upper right corner of the "Family" page to enter the device addition page.
3. Add battery: Click the loaded serial number, scan the SN code of the meter reader module, or manually enter the serial number.
4. Add meter reader: Click the loaded serial number.

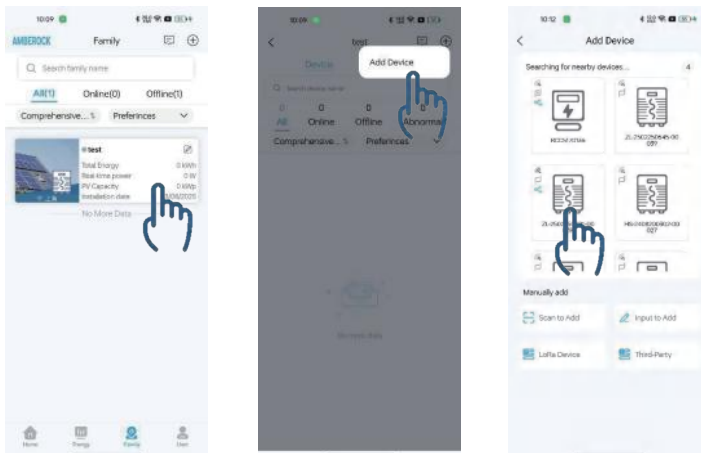

Note: Smart meter reader: P1: voltdeer- SMeter-RS02. Voltdeer: SMeter-RC01

# 10 APP

## 10.5.2 Network mode configuration

Ensure that the mobile phone's location and Bluetooth permissions are enabled. Then select or enter the Wi-Fi name and password to connect to the network. Click "NEXT" to proceed and wait for approximately 10 seconds for successful network configuration. If network configuration fails, check if the mobile phone's location and Bluetooth permissions are enabled, then follow the prompts again.

Note: The smart meter reader and the device must be on the same local area network (LAN).

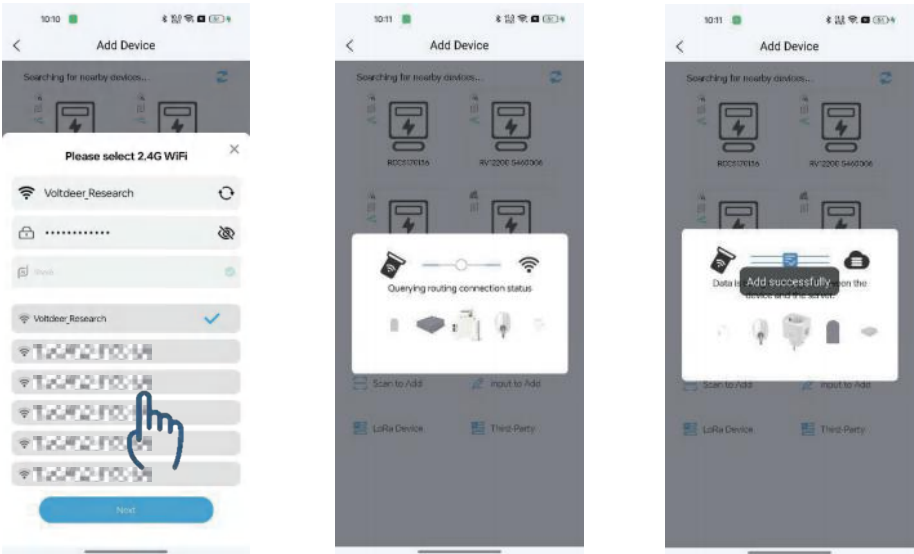

## 10.6 Check collector status

Return to the home page, click "Power Station" to enter the power station display page. Select the power station and click to enter the device viewing page. Click "Collector" to access the collector status page. Pull down to refresh the page. If the green "Online" indicator in the upper right corner of the collector is lit, the collector is in use. If it shows gray "Offline", the collector is not in use. Click the "Devices" page again and wait for two minutes. Pull down to refresh the page to display the list of power station devices.

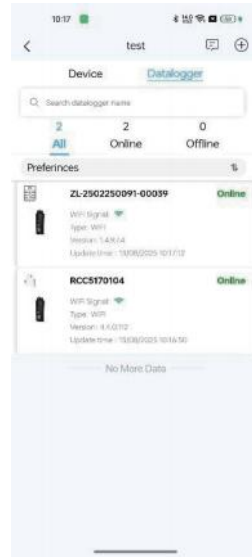
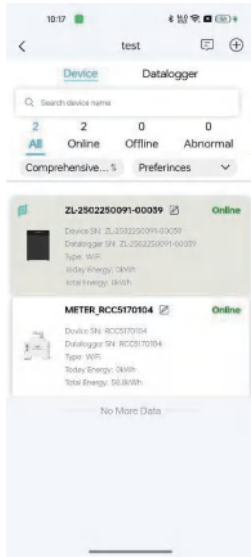

## 10.7 Data browsing

### 10.7.1 Understand data browsing

The app summarizes relevant monitoring and operation data of the associated power stations based on the login account type or linked business. It supports browsing of multiple power stations or a single power station. You can filter data by date to quickly view data charts and ranking systems, meeting your needs for overall monitoring and analysis of power stations.

### 10.7.2 Function Overview

Check today's energy output, status, total energy, total income, and installation date. Display the collection and summary of power station data, including "Power Station Status Announcement" and "Power Station Distribution" data. The "Power Station Status Announcement" classifies and filters the current status of each power station. The "Power Station Distribution" displays the location of power stations based on latitude and longitude for quick access to basic information and status.

## 10.8 Device Settings

### 10.8.1 Parameter Settings

To facilitate device management, you can set device parameters via the app.

Function description: Remote settings require the user to first add the device, which must be connected to the network and powered on (online status). Default parameters are pre-configured and do not require manual setting. Under compliance with local regulations, the "Grid-connected Output Power" can be set to a maximum of 2400W.

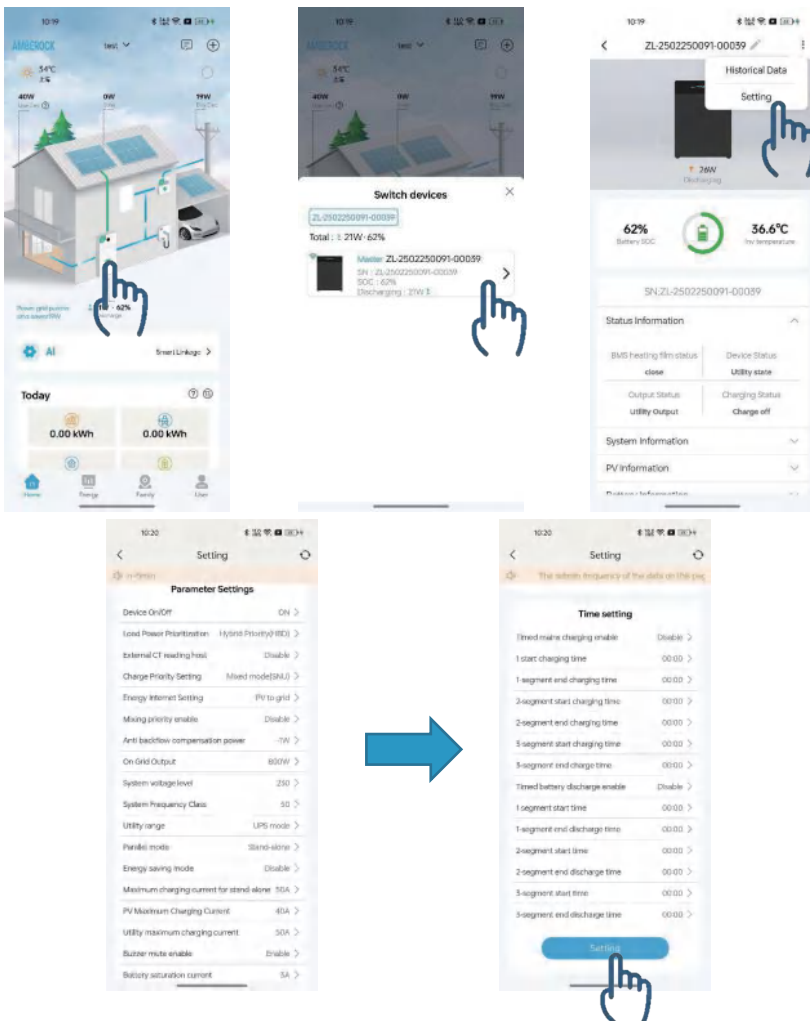

## 10.8.2 Zero Feed-in Setting

Select [Zero Feed-in] based on local grid policies and personal needs.

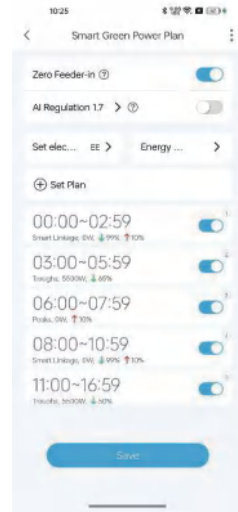
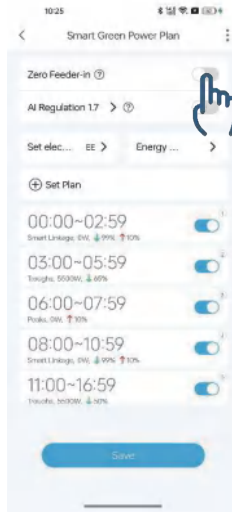
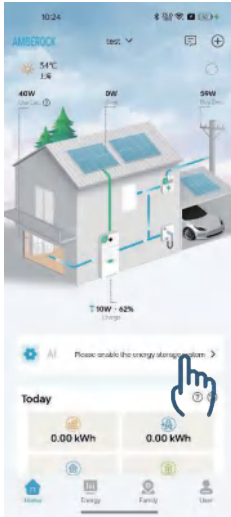

## 10.8.3 AI Regulation Setting

After setting the latest version of AI regulation, the app will automatically generate dynamic charging and discharging strategies based on local grid conditions, aiming to purchase electricity at low prices, discharge at high prices, and maximize photovoltaic utilization.

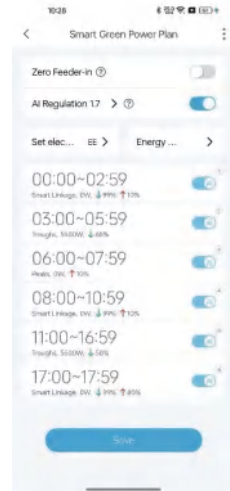
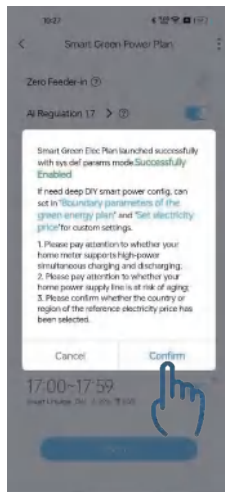
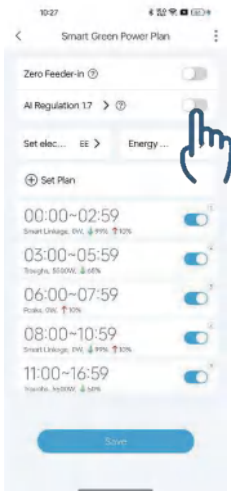

## 10.8.4 Electricity Price Setting

You can select the country and local grid company, set the wholesale price, and enter the tariff rate or VAT value. The app will calculate your income accordingly.

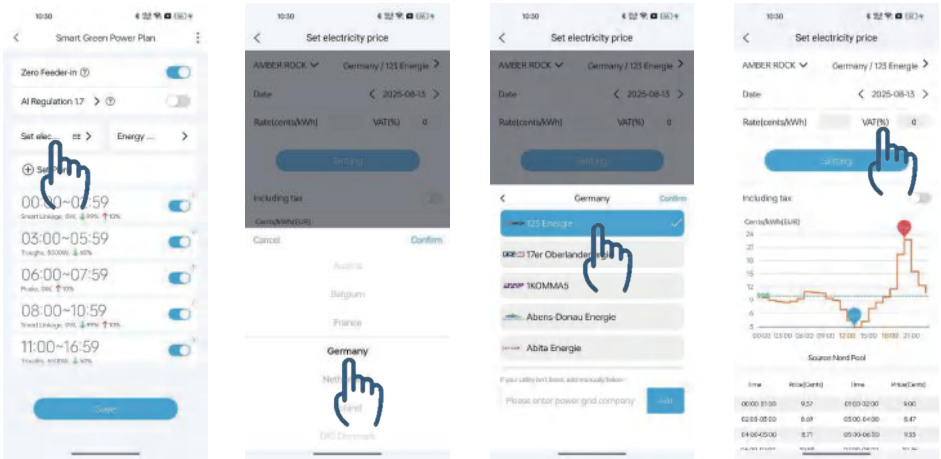

## 10.8.5 Custom Mode Setting

You can manually set charging and feed-in schedules.

Note: The default maximum feed-in power is 800W. If set to exceed 800W, it will still operate at 800W. Users can increase the maximum grid-connected power to 2400W in accordance with local regulations (see 9.8.1 Parameter Settings - [Grid-connected Output Power]).

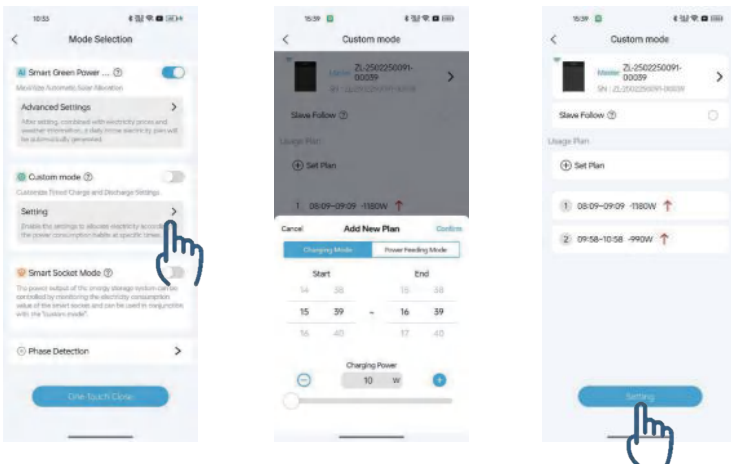

## 10.8.6 Automatic Detection Function

This product is equipped with an automatic test system to verify the maximum/minimum frequency and maximum/minimum voltage protection functions specified in the SPI, ensuring the reliable operation of the interface protection function.

### Operation Process

#### 1.Select Grid-Connection Standard

Enter the "Settings - Parameter Settings" interface, and select the corresponding standard (e.g., CEI 0-21) in the "Grid-Connection Standard" option.

#### 2.Start Grid-Connection Self-Test

Click the "Grid-Connection Self-Test" option in the "Parameter Settings" interface to enter the self-test page.

#### 3.Execute Self-Test

Click the "Start Self-Test" button, and the system will automatically perform the test. At this time, the interface will display "Self-test in progress, please wait".

#### 4.View Self-Test Result

After the self-test is completed, if "Self-Test Successful" is displayed, you can click the "View Report" button.

#### 5.View Detailed Report

In the self-test report, you can view parameter values such as action thresholds and action times for various protection functions including overvoltage, undervoltage, overfrequency, and underfrequency. You can also click "Download Report" to save the report.

# 11 Frequently Asked Questions (FAQs)

---

## 1. What precautions should be taken when storing the device?

Before storing the device, turn it off and disconnect all connecting cables. Store it in a dry and well-ventilated environment. The storage temperature should be controlled between  $-5^{\circ}\text{C}$  and  $35^{\circ}\text{C}$ , and the relative humidity between 0% and 60%. Avoid placing the device near fire sources, heat sources, water sources, or corrosive substances.

For long-term storage, maintain the battery power between 40% and 70%. After storage, it is recommended to inspect and charge the device every 3 months.

## 2. If the voltage and current of the electrical equipment are within the rated range but the device still fails to work normally, how to handle it?

Confirm that the power of a single electrical device is less than the rated output power of the corresponding interface. Ensure that the total power of all electrical devices connected to the battery is less than the rated output power of the device.

## 3. How to upgrade the device?

The device can be upgraded via the AMBERROCK app. Before upgrading, ensure the device has sufficient power and a stable network connection. Do not use the device or disconnect the network during the upgrade.

## 4. Can third-party PV panels be used to charge the device?

Yes. If using third-party PV panels, confirm that the panel interface is MC4 or use reliable adapters (not included in the product package; users need to purchase separately). Ensure the single MPPT input voltage is between 10V and 100V. For safety reasons, it is recommended to use PV panels produced or recommended by Voltdeer. Voltdeer is not liable for any losses caused by the use of third-party accessories.

## 5. In a low-temperature environment, the battery still cannot charge after enabling the heating film. How to handle it?

The device cannot charge when the cell temperature is below the rated value. After enabling the heating film, the battery will automatically heat up. Once the cell temperature reaches the appropriate level, the charging function will resume. Please wait patiently for the charging function to recover after enabling the heating film.



# Voltdeer Warranty Card

## User Information

Name: \_\_\_\_\_

Tel: \_\_\_\_\_

Email Add: \_\_\_\_\_

Postal Code: \_\_\_\_\_

Add: \_\_\_\_\_

## Product Information

Model: \_\_\_\_\_

Serial Number: \_\_\_\_\_

## Seller Information

Seller Name: \_\_\_\_\_

Tel: \_\_\_\_\_

Purchase Date: \_\_\_\_\_

Thank you for purchasing the Voltdeer product. Before use, please carefully read the user manual to understand the product precautions and usage methods. If the product malfunctions, please contact the local distributor or send an email to [wdkj@voltdeer.com](mailto:wdkj@voltdeer.com).

For more information, please scan the QR code below to visit the Voltdeer official website.



 Shanghai Voltdeer Technology Co.,Ltd.  
Building 8, Lane 739, Kangwei Road,  
Kangqiao Town, Pudong New Area, Shanghai

 [wdkj@voltdeer.com](mailto:wdkj@voltdeer.com)  
 [www.voltdeer.com](http://www.voltdeer.com)  
 +86-21-50880510

Importer of this product: